



McKenzie Valve & Machining Company

145 Airport Rd
McKenzie, TN 38201
731-352-5027

www.McKenzieValve.com

1", 2" & 3" THREADED BALL VALVES

January 2009

Threaded ball valves are used for top loading and unloading on tank cars. These valves are attached to the top fittings flange by NPT threads. The top side of the valve is supplied with another NPT connection. The valve is supplied complete with a handle. Standard Valve is supplied seal welded without joint gasket (body seal).

UNNR – 1", 2" & 3" Threaded Valves

Valve Size: 1", 2" or 3"
Port: Full Port
Maximum Pressure: 500 psi
Maximum Temperature: 400°F
Mounting: Female NPT Threads
Seats/Seals: Teflon
Body/Tim: 316 Stainless Steel
AAR Approval Number: E-077035



PRESSURE – TEMPERATURE CURVE

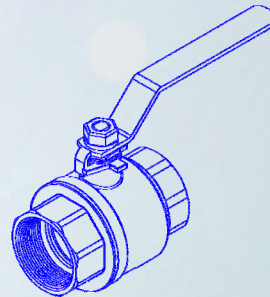
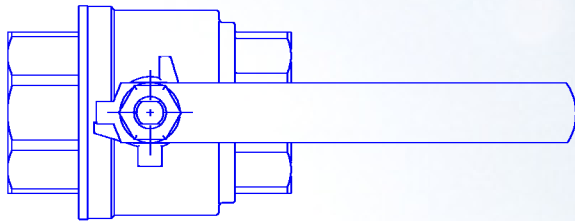
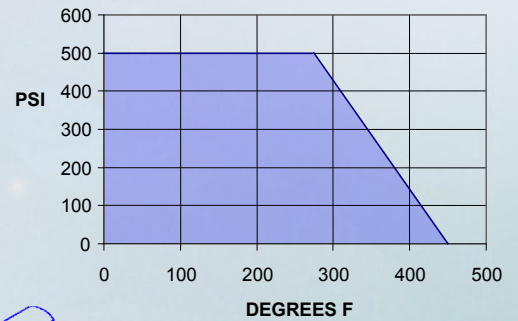

COMPONENTS

Number	Component Name	Material
1	BODY	CF8M
2	END CAP	CF8M
3	BALL	CF8M/316
4	SEAT	PTFE
5	JOINT GASKET	PTFE if app.
6	THRUST WASHER	PTFE
7	STEM PACKING	PTFE
8	GLAND NUT	SST
9	STEM PACKING	SST
10	STEM WASHER	SST
11	STEM NUT	SST
12	HANDLE	SST

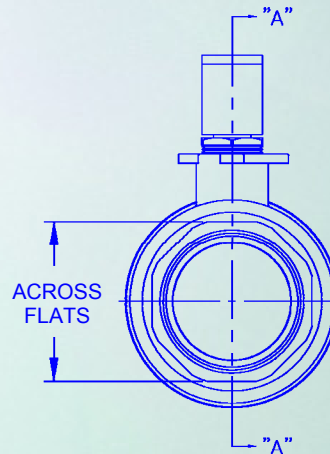
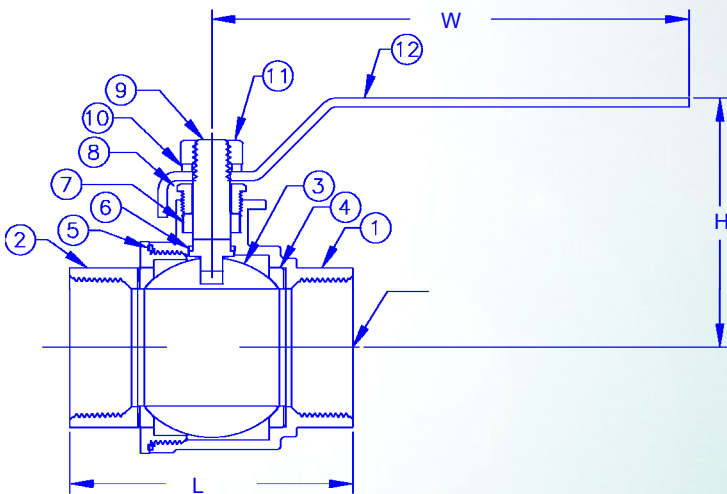

SECTION "A-A"

ORDERING INFORMATION

Connection Size	Part Number
1" NPT x 1" NPT	MV50001-01
2" NPT x 2" NPT	MV50002-01
3" NPT x 3" NPT	MV50003-01

DIMENSIONS

	H	L	W	FLATS
1"	2.68	3.03	5.12	1.54
2"	4.25	4.72	7.17	2.68
3"	5.35	6.36	9.84	3.88

FLOW RATE
GPM @ Δ1PSI

	Cv
1"	110
2"	480
3"	1200



All dimensions are reference